

□ ANZ 05

Display and configuration device



Product Information

Table of contents

1	Application	4
2	Functions	4
2.1	Display of measured values.....	4
2.2	Display of operating and fault messages.....	4
2.3	Configuration options of RCM devices	5
2.3.1	General	5
2.3.2	Monitoring of operating current.....	5
2.3.3	Residual current monitoring.....	5
2.3.4	Warning and triggering thresholds.....	6
2.3.5	Hysteresis range.....	7
2.3.6	Delay times	7
2.4	Relay functions	8
3	Device dimensions and connections	8
3.1	Device dimensions.....	8
3.2	Connection schematic	9
3.3	Bus architecture and connection of optional devices	10
3.4	Application examples.....	10
4	Assembly and connection	12
5	Buttons and display	12
6	Messages / communication interfaces	13
7	Technical specifications	14

1 Application

The ANZ 05 is a bus-capable display and configuration device for CAN-bus-capable devices from ESA Elektroschaltanlagen Grimma GmbH. It has two communication interfaces (CAN0 and CAN1) and communicates over them with other devices connected to the bus.

The ANZ 05 can process signals fed into the bus, for instance from third-party systems. These could be systems for heating, ventilation and air conditioning, signals from the KNX(EIB) bus or also from PLC controllers.

The device also has two relays, the function of which can be set using the menu.

2 Functions

2.1 Display of measured values

In the display (full graphics display), measurements of the following devices can be displayed, including:

- Voltage monitoring device with change-over control SPR-107-V.4
- Insulation, load and temperature monitoring device ILT-107-V.4
- Residual and operating current monitoring device of type RCM-W8/W24
- Residual current monitoring device of type RCM-W6
- Multifunctional change-over and monitoring device UEI-710-V.5

2.2 Display of operating and fault messages

The ANZ 05 can also display incoming status messages from connected devices using freely configurable messages.

Operating states are recorded via the CAN bus. Messages are displayed as full graphics display, combined with a visual LED signal and, for warning and fault messages, a horn signal.

Each expected operating state is assigned one of three signal levels:

- Operation (BETRIEB)
- Warning (WARNUNG)
- Malfunction (STÖRUNG)

A large, backlit full graphic display presents the information in a clearly structured manner. The messages texts can be used for projects freely with a project development tool. After acknowledging the alarm, it is possible to switch between display of the measurements and the messages. Up to 1000 different events can be displayed. The messages are output as four-line text.

2.3 Configuration options of RCM devices

2.3.1 General

The following devices can be configured with the ANZ 05:

- Residual current monitoring device of type RCM-W6
- Residual and operating current monitoring device of type RCM-W8/W24

2.3.2 Monitoring of operating current

Depending on the type of current transformer, operating currents can be measured via each channel of a RCM-W8/W24 monitoring device. The currents of the consumers are recorded by the connected current transformers.

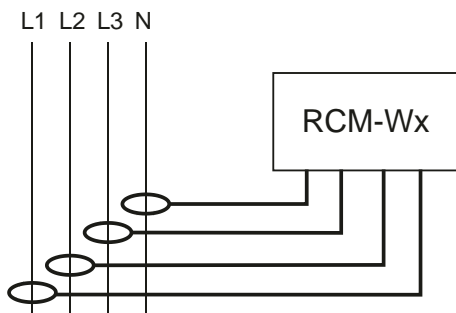

Figure 1: Simplified illustration of operating current measurement

The ANZ 05 displays the ongoing operating current values.

2.3.3 Residual current monitoring

Residual currents can be measured on any of the channels of the RCM devices. Currents flowing to earth or through other paths are recorded by the current transformer, such as:

- In the incoming feeders
- In the outgoing feeders (consumers and systems)
- Stray currents in TN-S systems (PEN and N lines)
- At central earthing points

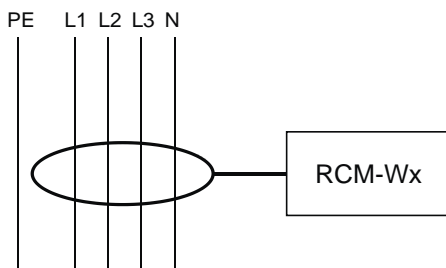

Figure 2: Simplified monitoring of residual current

The ANZ 05 displays the ongoing residual current values.

2.3.4 Warning and triggering thresholds

Warning and triggering thresholds are configurable limit values that can be adjusted according to the currents to be measured.

If any of these thresholds are reached, the relevant RCM device sends a message via the CAN bus. The relays of the ANZ 05 are also set if they have been configured accordingly. Warning and triggering thresholds can be set separately for each channel.

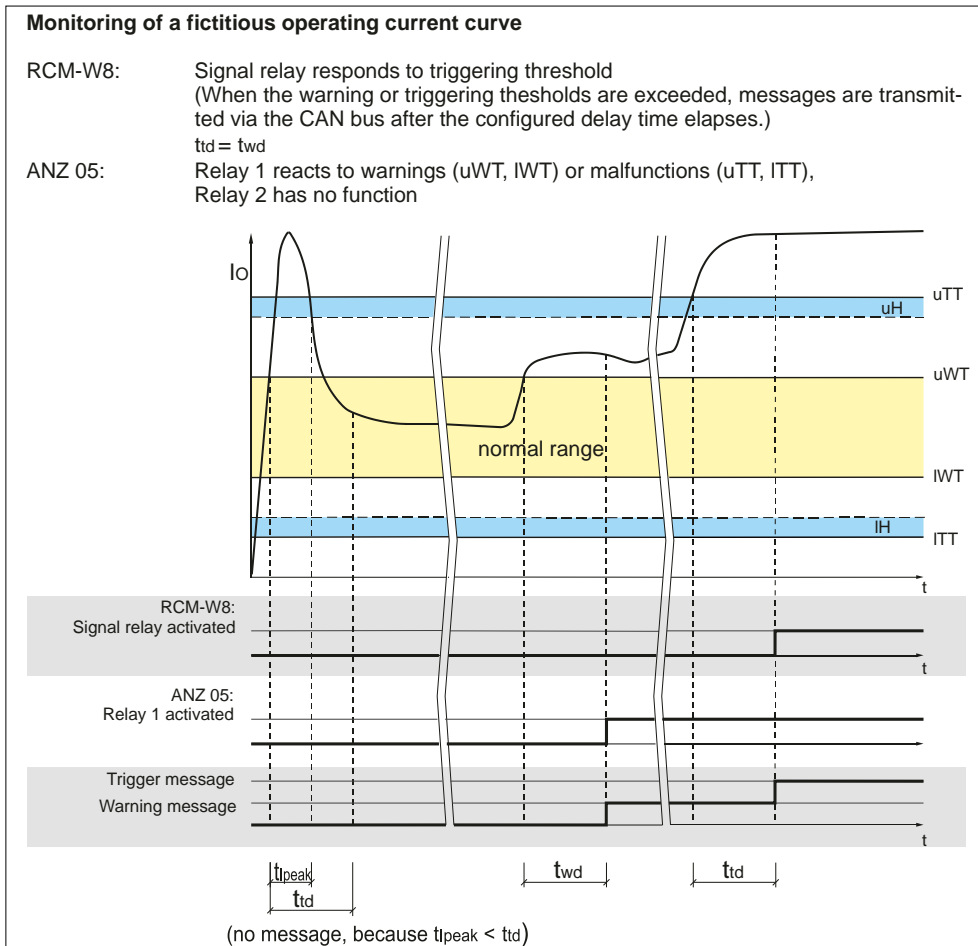

Figure 3: Example operating current curve

- I_o Operating current
- t Time
- t_{peak} Duration of inrush peak current of a consumer
- t_{td} Delay time for trigger messages (configurable), $> t_{peak}$ - otherwise a message is sent!
- t_{wd} Delay time for warning messages (configurable)
- u_{TT} Upper triggering threshold (configurable)
- u_H Upper hysteresis range (configurable, see chapter 2.3.5 on page 7)
- u_{WT} Upper warning threshold (configurable)
- I_{WT} Lower warning threshold (configurable)
- I_H Lower hysteresis range (configurable, identical to upper hysteresis range)
- I_{TT} Lower triggering threshold (configurable)

For residual current monitoring, only the upper warning and triggering thresholds need to be evaluated for each channel.

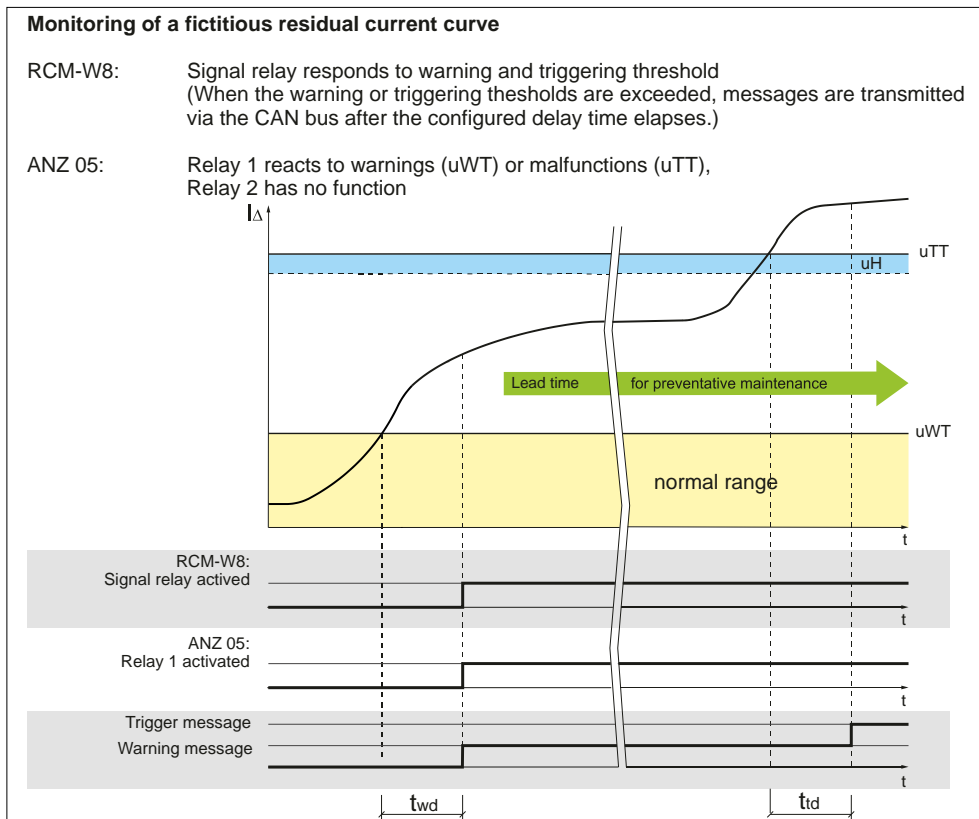

Figure 4: Example residual current curve

I_{Δ}	Residual current
t	Time
t_{td}	Delay time for trigger messages (configurable)
t_{wd}	Delay time for warning messages (configurable)
uTT	Upper triggering threshold (configurable)
uH	Upper hysteresis range (configurable, see chapter 2.3.5)
uWT	Upper warning threshold (configurable)

2.3.5 Hysteresis range

The upper and lower triggering thresholds have a configurable hysteresis range. The upper and lower hysteresis ranges are identical in size. The hysteresis ranges can be defined individually for each channel.

For example, if the measured operating current exceeds the upper triggering threshold and then falls below again, the trigger message will be reset only after the operating current falls below the hysteresis range.

2.3.6 Delay times

The following delay times can be set on the RCM devices for residual and operating current monitoring:

- Delay time for trigger messages (t_{td})
- Delay time for warning messages (t_{wd})
- Reset delay time for trigger and warning messages (t_{rd})

2.4 Relay functions

Two relays integrated in the ANZ 05 can be used for various purposes:

- As signal relay in case the warning or triggering thresholds (RCM devices) are exceeded
- As signal relay for output of device faults (device types SPR-107-V.4, ILT-107-V.4, UEI-710-V.5)
- For special evaluation of fault messages of SPR-107-V.4 and UEI-710-V.5 devices
It is possible to evaluate the failure of line 1 in systems according to DIN VDE 0100-710 (VDE 0100 Part 710):2002-11 (use in hospitals) so that the relays output a short impulse (1 s) after a time delay. This can effect targeted load shedding, for instance. A requirement is that the ANZ 05 is operated on a secure power supply (line 2 or additional power supply).
- For evaluation of panel failure (self-monitoring)

The relay can operate either according as NO or NC contact.

3 Device dimensions and connections

3.1 Device dimensions

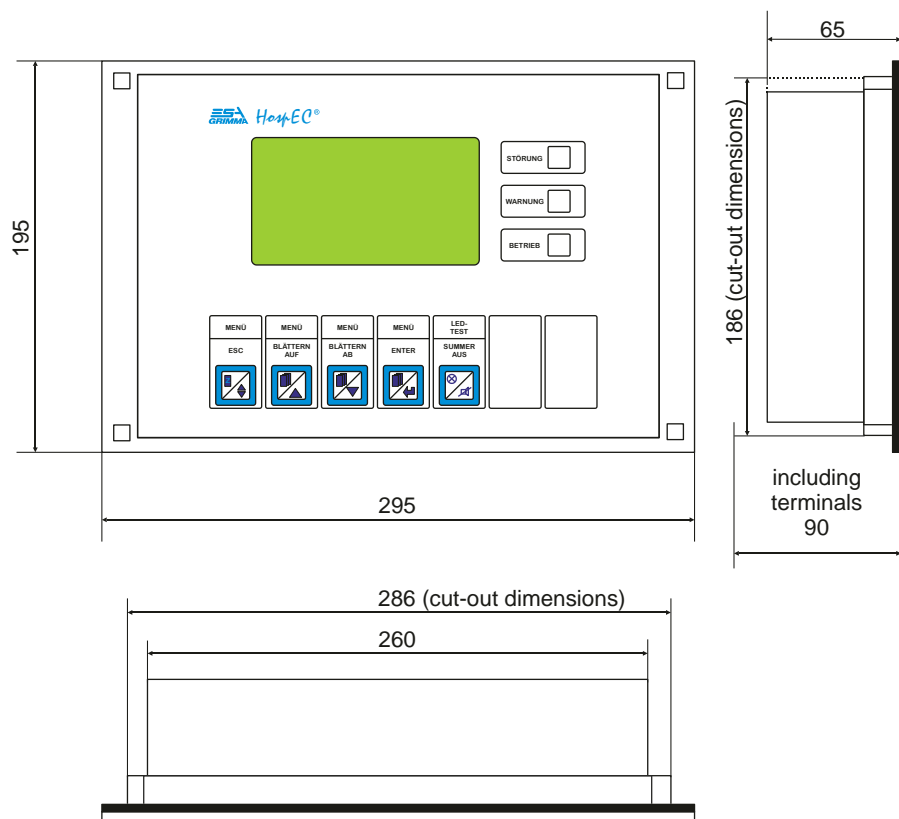

All dimensions in mm

Figure 5: Device view and dimensions

3.2 Connection schematic

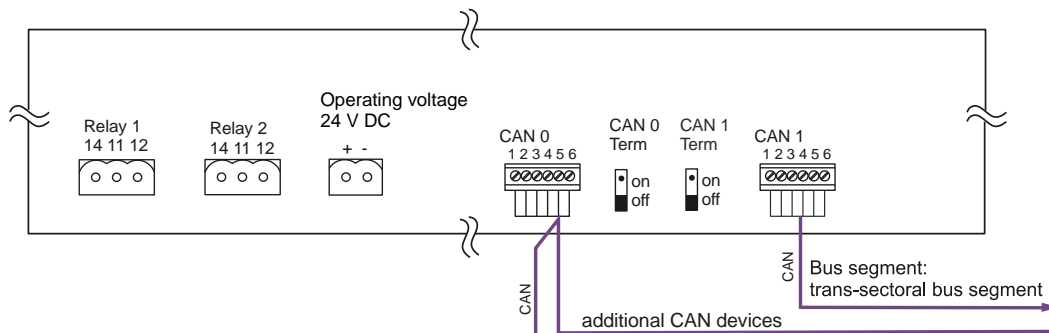

Figure 6: Connection schematic

CAN 0 / CAN 1	Pin assignment	Wire colour
1	24 V DC GND	Blue
2	CAN low	White
3	Shield	shield wire
4	CAN high	Yellow
5	+ 24 V DC	Red
6	Shield	Shield wire

Table 1: Pin assignment CAN 0 / CAN 1

NOTE: Pins 3 and 6 are connected internally in devices and terminal adapters ("IN" and "OUT").

Relay 1 / relay 2	State	Contacts (closed)	
Open-circuit principle (NO = normally open): 	Device off	11	12
	Device on / no messages or faults	11	12
	Device on / warning or trigger message active or fault is present	11	14
Closed-circuit principle (NC = Normally closed): 	Device off	11	12
	Device on / no messages or faults	11	14
	Device on / warning or trigger message active or fault is present	11	12

Table 2: Open-circuit or closed-circuit principle of the relays

3.3 Bus architecture and connection of optional devices

NOTE: For a detailed description of the bus system, see the installation instructions for the standard field bus (CAN) from ESA Elektroschaltanlagen Grimma GmbH.

3.4 Application examples

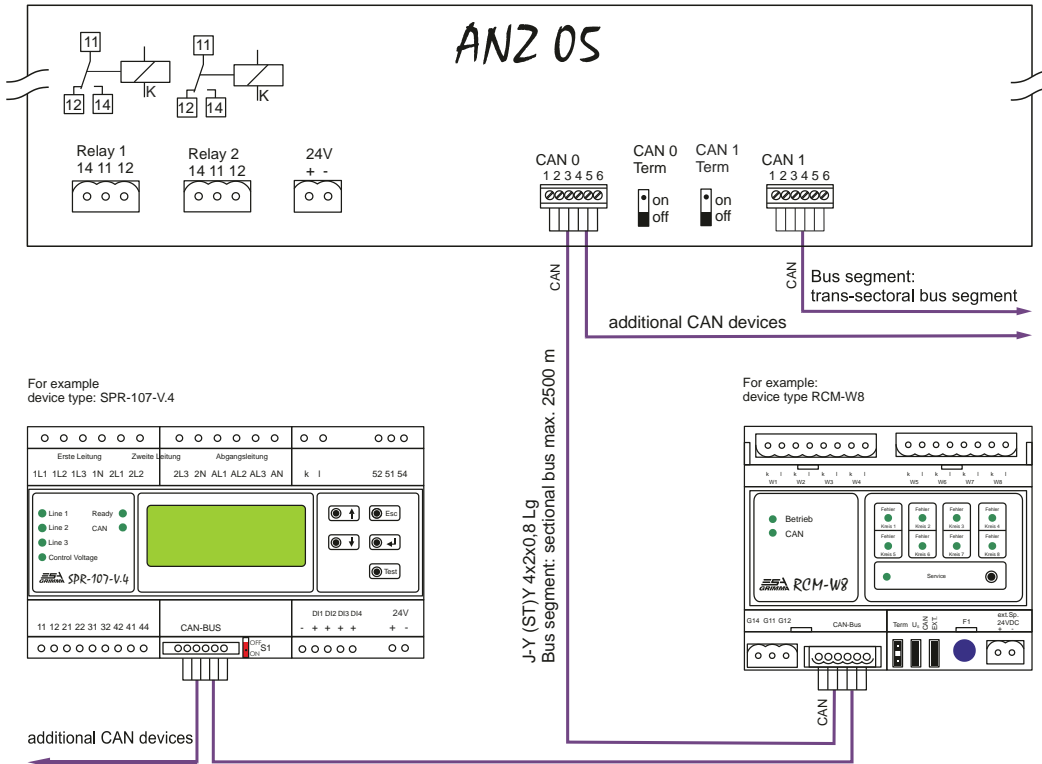

Figure 7: Application example with SPR-107-V.4 and RCM-W8

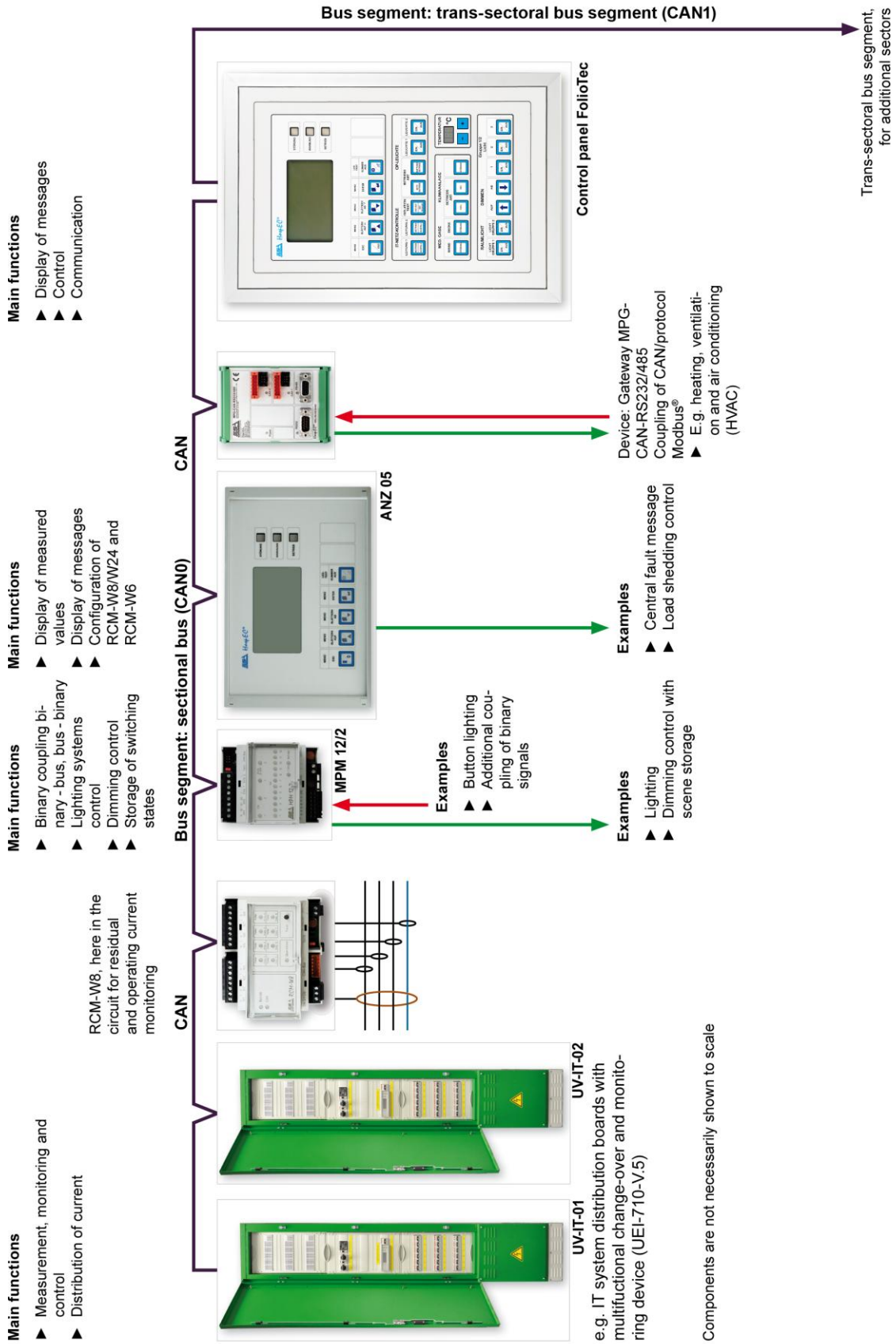

Figure 8: Application example of a possible coupling

4 Assembly and connection

The ANZ 05 is installed in distribution boards or hollow-walls, for instance. Only qualified electricians are permitted to assemble, connect and start-up the system. All such work must be performed in full compliance with the pertinent safety regulations.

Connect the ANZ 05 according to the connection diagram. Observe the ratings of the individual connections. Observe the technical specifications of the device.

NOTE: Due to the associated modifications for the respective application, the initial start-up of the ANZ 05 should be performed by an authorized service technician from ESA Elektroschaltanlagen Grimma GmbH.

5 Buttons and display

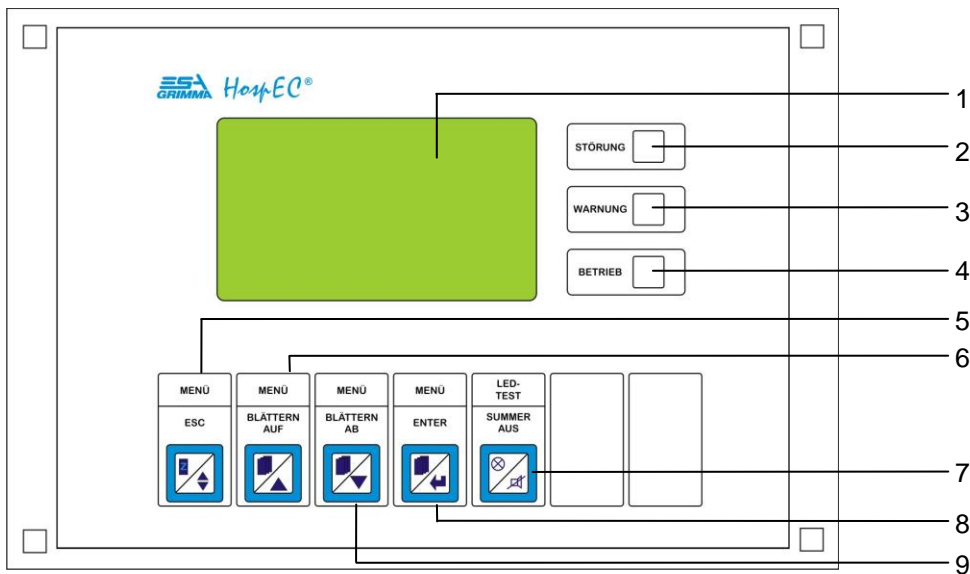

Figure 9: ANZ 05 – front view

- | | |
|--------------------------------------|-------------------------------|
| 1 Display (LCD) | 6 Button "BLÄTTERN AUF" (Up) |
| 2 Status LED "STÖRUNG" (Malfunction) | 7 Button "LED TEST" |
| 3 Status LED "WARNUNG" (Warning) | 8 Button "ENTER" |
| 4 Status LED "BETRIEB" (Operation) | 9 Button "BLÄTTERN AB" (Down) |
| 5 Button "ESC" | |

6 Messages / communication interfaces

Operating and fault messages of the devices to be monitored are indicated by the LEDs and shown on the screen of the ANZ 05. They can also be transmitted via the potential-free exchanger of the integrated signal relays, if they are configured accordingly.

The CAN interface can be used to transmit data as well as the current operational and fault statuses to external peripheral equipment (e.g. panels) and to connect the device to the building services control system.

The following messages can be displayed:

- Measured values of the devices to be monitored
- Measured values of the connected air conditioning units
- Overloading in IT systems
- Overtemperature of IT system separating transformers
- Insulation fault in AC 230 V IT system
- Insulation fault in AC 24 V IT system
- Address conflict
- Faulty outgoing circuit for connected insulation fault detection system
- Device error of the monitored devices
- Failure of the monitored lines (SPR-107-V.4 or UEI-710-V.5)

7 Technical specifications

Operation	
Supply voltage U_s	DC 24 V (PELV)
Operating range	0.85 ... 1.25 x U_s
Internal consumption	approx. 6 W
Display and controls	
Graphic display (LCD)	240 x 108 pixels
Foil surface	resistant to detergents and disinfectants
Controls	5 buttons (foil keyboard backlit)
Transparent displays, backlit	Operation (BETRIEB), Warning (WARNUNG) and Malfunction (STÖRUNG)
Other signallers	Horn
Signal relay	
Two signal relays	fault message or configurable for load shedding control
Switching elements	1 exchanger
Rated contact voltages	AC 250 V / DC 30 V
Making capacity	AC / DC 5 A
Functionality	configurable: normally open or normally closed
Time-delayed triggering (e.g. for load shedding control)	configurable 0 ... 99 s
trigger impulse	1 s
Communication interface / protocol	
Interface / protocol	2 x CAN / CAN (2.0) acc. to ISO 11898
Electromagnetic compatibility (EMC)	
Immunity acc. to EN 61000-6-2: March 2000, Generic standards – Immunity for industrial environments	
Emissions acc. to EN 50081-1	
Environmental conditions	
Ambient temperature (operation) acc. to EN 61557-8:1997	-5°C to +45°C
Ambient temperature (storage) acc. to EN 61557-8:1997	-25°C to +70°C
Climatic conditions class acc. to IEC 721	3K5, no condensation or icing
Installation specifications	
Installation position	any
Assembly	in control cabinet doors/hollow-walls
Cut-out dimensions of housing in mm (H x W)	186 x 286
Installation depth (including terminals)	90 mm
Dimensions of front plate in mm (H x W)	195 x 295
Connection type	Plug terminals
Wire size / single-wire / fine-wire	0.2 ... 2.5 mm ² (AWG 24-11)
Protection class acc. to DIN EN 60529 for panel attachment / terminals (installation housing)	IP54 / IP20
Flammability class	UL94V-0
Weight	Approx. 1300 g
Order information	
ANZ 05	Item no. 0080160

**ESA Elektroschaltanlagen
Grimma GmbH**

Broner Ring 30
D-04668 Grimma

Tel.: +49 (0) 3437 9211-0
Fax: +49 (0) 3437 9211-26

E-mail: info@esa-grimma.com
Internet: www.esa-grimma.com

ANZ 05
Display and configuration device

Product Information (PI)

Published by:
ESA Elektroschaltanlagen
Grimma GmbH.

Reprint only with publisher's permission. All
rights reserved. Subject to change without
notice.

Revision date: 11-2010